

Corinthian Specifications

- 3 Handled Quarter turn mixer
- Provides Hot, Cold and Purified water from a single mixer
- Coded indices
- Dedicated handle and spout outlet for purified water
- Includes an integrated Filter System
- Exceptional Filtration capability
- Machined brass body
- Biflow spout
- Meets all certification approval requirements
- Attractive design
- Compatible with most Franke sinks
- Requires 35mm tap hole
- Optional Corian/Teak handles available at extra cost
- Fully guaranteed with nationwide servicing*

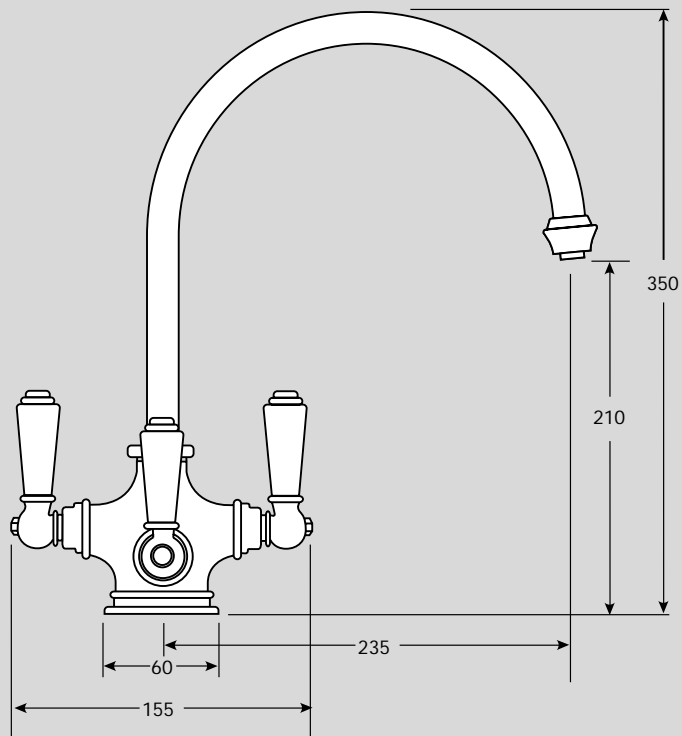

Material:	Solid brass machined body and tubular brass spout	
Type:	Quarter turn mixer	
Spout:	Biflow tubular spout with bayonet and screw fitting	
Tails:	Flexi tails	
Tap Height:	210 and 350	
Spout Reach:	235	
Handle Width:	155	
Colours:	Chrome, Gold Finish, Nickel, Pewter or Nickel/Gold	
Maximum Water Pressure:	75 PSI (5 bar)	
Maximum hot-water Temperature:	70°C	
Recommended hot water Temperature:	65°C	
Guarantee:-	Ceramic disc:	5 year
	Surface:	1 year
Joints:	It is recommended that compression fittings are used to link the tap to the supply.	

Some taps may require bracing to avoid flexing of the sink ledge.

Tails:

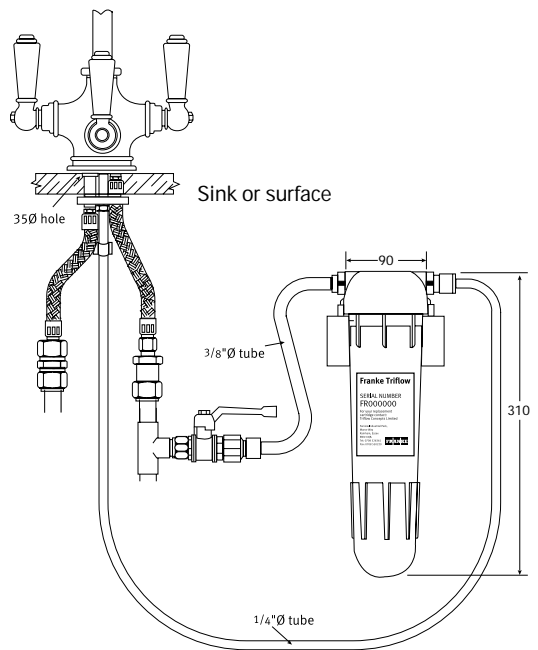

Valve Mechanism: (x3)

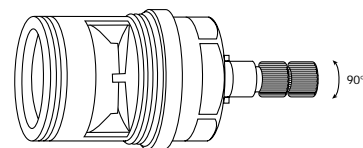

*Avilion: 01708 526361

All Franke taps are designed to conform with Water Research Council requirements

NB. Ceramic disc taps in certain installations or where there is a low head of water (below 3 metres) may not provide adequate flow rates. You are advised to check with your supplier.